

# Milling · Fräsen

Indexable Milling Tools · Wendeplattenfräser

## Square shoulder milling tools · Eckfräser

Kr:90°



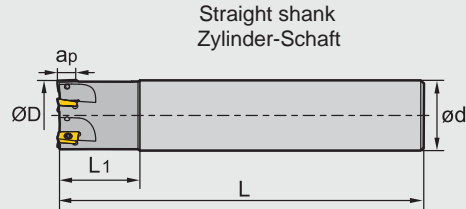

EMP01 **P** **M** **K** **N**



### Specification of tools · Werkzeug Beschreibung

	Type Typ	Stock Lager	Dimensions (mm) Abmessungen					No. of teeth Zähne	Weight Gewicht (kg)
			Ø D	Ø d	L	L <sub>1</sub>	ap <sub>max</sub>		
EMP01	012-G16-AP11-01	●	12	16	85	25	10.5	1	0.1
	012-G16-AP11-01C	●	12	16	85	25	10.5	1	0.1
Straight shank	016-G16-AP11-02	●	16	16	90	25	10.5	2	0.1
	016-G16-AP11-02C	●	16	16	90	25	10.5	2	0.1
Zylinder- Schaft	020-G20-AP11-02	●	20	20	100	30	10.5	2	0.2
	020-G20-AP11-02C	●	20	20	100	30	10.5	2	0.2
	020-G20-AP11-03	●	20	20	100	30	10.5	3	0.2
	020-G20-AP11-03C	○	20	20	100	30	10.5	3	0.2
	025-G25-AP11-03	●	25	25	115	35	10.5	3	0.4
	025-G25-AP11-03C	●	25	25	115	35	10.5	3	0.4
	025-G25-AP11-04	●	25	25	115	35	10.5	4	0.4
	025-G25-AP11-04C	○	25	25	115	35	10.5	4	0.4
	032-G32-AP11-04	●	32	32	125	40	10.5	4	0.7
	032-G32-AP11-04C	●	32	32	125	40	10.5	4	0.7
025-G25-AP16-02	●	25	25	115	35	15.5	2	0.4	
025-G25-AP16-02C	●	25	25	115	35	15.5	2	0.4	
032-G32-AP16-03	●	32	32	125	40	15.5	3	0.7	
032-G32-AP16-03C	●	32	32	125	40	15.5	3	0.7	
040-G32-AP16-03	●	40	32	130	42	15.5	3	0.7	
040-G32-AP16-03C	●	40	32	130	42	15.5	3	0.7	
040-G32-AP16-04	●	40	32	130	42	15.5	4	0.8	
040-G32-AP16-04C	●	40	32	130	42	15.5	4	0.8	
050-G32-AP16-05	●	50	32	135	45	15.5	5	1.0	
050-G32-AP16-05C	●	50	32	135	45	15.5	5	1.0	
063-G32-AP16-06	●	63	32	135	45	15.5	6	1.4	
063-G32-AP16-06C	●	63	32	135	45	15.5	6	1.4	

### Spare Parts · Ersatzteile

Diameter Durchmesser Ø D	Insert WSP	Screw Schraube	Wrench Schlüssel	
				
Ø12-Ø32	AP11	I60M2.5x6.5T	WT08IP	--
Ø25-Ø63	AP16	I60M4x8.4	--	WT15IS



● Ex Stock / ab Lager ○ On demand / auf Anfrage

### Square shoulder milling tools · Eckfräser

Kr:90°



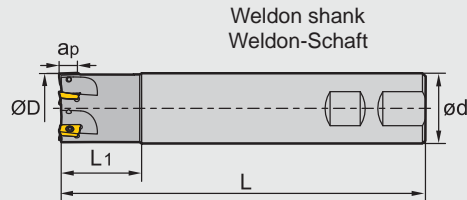

EMP01 **P** **M** **K** **N**



### Specification of tools · Werkzeug Beschreibung

	Type Typ	Stock Lager	Dimensions (mm) Abmessungen					No. of teeth Zähne	Weight Gewicht (kg)
			Ø D	Ø d	L	L <sub>1</sub>	ap <sub>max</sub>		
EMP01	012-XP16-AP11-01	•	12	16	85	25	10.5	1	0.1
	012-XP16-AP11-01C	•	12	16	85	25	10.5	1	0.1
Weldon shank	016-XP16-AP11-02	•	16	16	90	25	10.5	2	0.1
	016-XP16-AP11-02C	•	16	16	90	25	10.5	2	0.1
Zylinder-Schaft	020-XP20-AP11-02	•	20	20	100	30	10.5	2	0.2
	020-XP20-AP11-02C	•	20	20	100	30	10.5	2	0.2
	020-XP20-AP11-03	•	20	20	100	30	10.5	3	0.2
	020-XP20-AP11-03C	○	20	20	100	30	10.5	3	0.2
	025-XP25-AP11-03	•	25	25	115	35	10.5	3	0.4
	025-XP25-AP11-03C	•	25	25	115	35	10.5	3	0.4
	025-XP25-AP11-04	•	25	25	115	35	10.5	4	0.4
	025-XP25-AP11-04C	○	25	25	115	35	10.5	4	0.4
	032-XP32-AP11-04	•	32	32	125	40	10.5	4	0.7
	032-XP32-AP11-04C	•	32	32	125	40	10.5	4	0.7
	025-XP25-AP16-02	•	25	25	115	35	15.5	2	0.4
	025-XP25-AP16-02C	•	25	25	115	35	15.5	2	0.4
	032-XP32-AP16-03	•	32	32	125	40	15.5	3	0.7
	032-XP32-AP16-03C	•	32	32	125	40	15.5	3	0.7
	040-XP32-AP16-04	•	40	32	130	42	15.5	4	0.8
	040-XP32-AP16-04C	•	40	32	130	42	15.5	4	0.8
	050-XP32-AP16-05	•	50	32	135	45	15.5	5	1.0
	050-XP32-AP16-05C	•	50	32	135	45	15.5	5	1.0
	063-XP32-AP16-06	○	63	32	135	45	15.5	6	1.4
	063-XP32-AP16-06C	○	63	32	135	45	15.5	6	1.4

### Spare Parts · Ersatzteile

Diameter Durchmesser Ø D	Insert WSP	Screw Schraube	Wrench Schlüssel	
				
Ø12-Ø32	AP11	I60M2.5x6.5T	WT08IP	--
Ø25-Ø63	AP16	I60M4x8.4	--	WT15IS

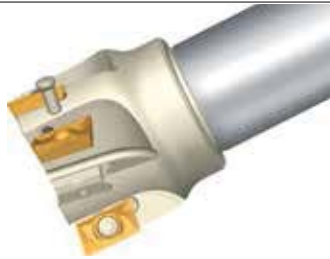

Applicable tool  
Werkzeug **B11-B18**

Tools code key  
Werkzeug ISO **B26-B27**

Grade selection guide  
Sortenauswahl **B19-B23**

Technical data  
Technische Daten **B215-B220**

B

Milling Tools  
Fräser

# Milling · Fräsen

## Indexable Milling Tools · Wendepplattenfräser

Applicable inserts · Wendeschneidplatten

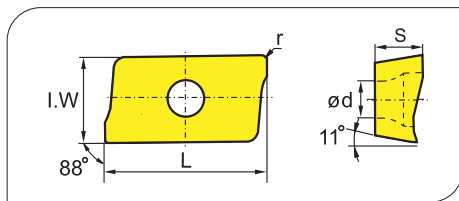

Workpiece Material Werkstoffe	Steel Stahl	Stainless Steel Rostfreier Stahl	Cast iron Gusseisen	Non-ferrite material Ne Metalle	Heat-resistant steel Warmfester Stahl
P	●	●	●	●	●
M	●	●	●	●	●
K	●	●	●	●	●
N	●	●	●	●	●
S	●	●	●	●	●

Insert shape Plattenform	Type Typ	Dimensions (mm) Abmessungen					CVD Coating CVD Beschicht.						PVD Coating PVD Beschicht.				Cermet Cermet	Carbide uncoat. unbe. Hartmetall								
		L	I.W	S	d	r	YBC301	YBC302	YBC401	YBM251	YBM253	YBM351	YBD152	YBD252	YBG102	YBG202		YBG205	YBG302	YBG152	YBG252	YNG151	YNG151C	YC30S	YD101	YD201
	APKT11T304-PF	12.24	6.5	3.6	2.8	0.4	○		●						●	●		●								
	APKT11T308-PF	12.24	6.5	3.6	2.8	0.8				○						●										
	APKT11T312-PF	12.24	6.5	3.6	2.8	1.2										○										
	APKT11T316-PF	12.24	6.5	3.6	2.8	1.6										○										
	APKT160408-PF	17.877	9.33	5.76	4.4	0.8	●		○		●				●		●									
	APKT11T304-PM	12.24	6.5	3.6	2.8	0.4	●	●	○	●	●				●	●		●								
	APKT11T308-PM	12.24	6.5	3.6	2.8	0.8	●	●		●	●	●	●	●	●	●	●	●								
	APKT11T312-PM	12.24	6.5	3.6	2.8	1.2				○					○	●										
	APKT11T316-PM	12.24	6.5	3.6	2.8	1.6				●					○	●										
	APKT160408-PM	17.877	9.33	5.76	4.4	0.8	●	●	●	●	●	●	●	●	●	●	●	●								
	APKT11T304-PR	12.24	6.5	3.6	2.8	0.4			●			○						○								
	APKT11T308-PR	12.24	6.5	3.6	2.8	0.8												○								
	APKT11T312-PR	12.24	6.5	3.6	2.8	1.2												○								
	APKT11T316-PR	12.24	6.5	3.6	2.8	1.6												○								
	APKT160408-PR	17.877	9.33	5.76	4.4	0.8												○								
	APKT11T304-LH	12.24	6.5	3.6	2.8	0.4																		●	●	
	APKT11T308-LH	12.24	6.5	3.6	2.8	0.8																		●	●	
	APET160402-LH	17.877	9.33	5.76	4.4	0.2																		○		
	APKT160408-LH	17.877	9.33	5.76	4.4	0.8																		●	●	
	APET160408PDFR-LH	17.877	9.33	5.76	4.4	0.8																		○		

● Ex Stock / ab Lager ○ On demand / auf Anfrage

### Chipbreaker Selection EMP01 · Spanbrecher Auswahl EMP01

Application Anwendung	Finishing Schlichten	Semi-Finishing Mittlere Bearbeitung	Roughing Schruppen
P	-PF	-PM	-PR
M	-PF	-PM	-PR
K	-PF	-PM	
AL	-LH		

### 1 Square shoulder milling 1 Eckfräsen

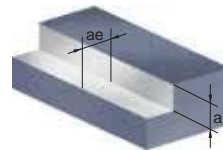

### Recommended cutting data · Empfohlene Schnittdaten

Workpiece material Werkstück Material	Hardness HB Härte	Grade Sorte	Cutting data Schnittdaten					
			V(m/min)	f(mm/z)			ae(mm)	
				-PF	-PM	-PR		
P Low-carbon steel Soft steel Niedrig legierter Kohlenstoffstahl Baustahl	≤180	YBM251 YBC301	320 (240-400)	0.1 (0.08-0.2)	0.2 (0.1-0.3)	0.25(0.2-0.35)	≤0.5D	
		YBM351	260 (180-380)	0.1 (0.08-0.2)	0.2 (0.1-0.3)	0.25(0.2-0.35)	≤0.5D	
		YBG202 YBG205	320 (200-400)	0.1 (0.08-0.2)	0.2 (0.1-0.3)	0.25(0.2-0.35)	≤0.5D	
		YBG302	280 (180-400)	0.1 (0.08-0.2)	0.2 (0.1-0.3)	0.25(0.2-0.35)	≤0.5D	
	High-carbon steel Alloy steel Hoch Leg. Kohlenstoffstahl Leg. Stahl	180-280	YBM251 YBC301	280 (210-380)	0.1 (0.08-0.2)	0.2 (0.1-0.3)	0.25(0.2-0.3)	≤0.5D
			YBM351	240 (160-320)	0.1 (0.08-0.2)	0.2 (0.1-0.3)	0.25(0.2-0.35)	≤0.5D
			YBG202 YBG205	280 (180-350)	0.1 (0.08-0.2)	0.2 (0.1-0.3)	0.25(0.2-0.3)	≤0.5D
			YBG302	260 (150-380)	0.1 (0.08-0.2)	0.2 (0.1-0.3)	0.25(0.2-0.35)	≤0.5D
	Alloy tool steel Leg. Werkzeugstahl	280-350	YBM251 YBC301	260 (180-350)	0.1 (0.08-0.2)	0.2 (0.1-0.3)	0.25(0.2-0.3)	≤0.5D
			YBM351	220 (150-280)	0.1 (0.08-0.2)	0.2 (0.1-0.3)	0.25(0.2-0.35)	≤0.5D
			YBG202 YBG205	260 (160-330)	0.1 (0.08-0.2)	0.2 (0.1-0.3)	0.25(0.2-0.3)	≤0.5D
			YBG302	240 (120-350)	0.1 (0.08-0.2)	0.2 (0.1-0.3)	0.25(0.2-0.35)	≤0.5D
M Stainless steel Rostfreier Stahl	≤270	YBM251	200 (120-270)	0.1 (0.08-0.2)	0.2 (0.1-0.3)	0.25(0.2-0.3)	≤0.5D	
		YBM351	180 (150-300)	0.1 (0.08-0.2)	0.2 (0.1-0.3)	0.25(0.2-0.3)	≤0.5D	
		YBG202 YBG205	200 (110-300)	0.1 (0.08-0.2)	0.2 (0.1-0.3)	0.25(0.2-0.3)	≤0.5D	
		YBG302	170 (100-280)	0.1 (0.08-0.2)	0.2 (0.1-0.3)	0.25(0.2-0.3)	≤0.5D	
K Cast iron Gusseisen	180-250	YBG102	220 (120-250)	0.1 (0.08-0.2)	0.2 (0.1-0.3)	-	≤0.5D	
		YBD152	240 (180-300)	-	0.2 (0.1-0.3)	-	≤0.5D	
		YBD252	200 (120-320)	-	0.2 (0.1-0.3)	-	≤0.5D	
N Al alloy Al Leg.	----	YD101	300-	-LH			≤0.5D	
		YD201	300-	0.2 (0.08-0.4)			≤0.5D	

Applicable tool  
Werkzeug

[B11-B18](#)

Tools code key  
Werkzeug ISO

[B26-B27](#)

Grade selection guide  
Sortenauswahl

[B19-B23](#)

Technical data  
Technische Daten

[B215-B220](#)

# Milling · Fräsen

## Indexable Milling Tools · Wendeplattenfräser

- 2 Slot milling
- 2 Nutenfräsen

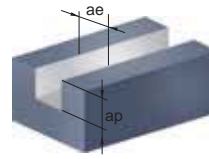

### Recommended cutting data · Empfohlene Schnittdaten

Workpiece material Werkstück Material	Hardness HB Härte	Grade Sorte	Cutting data Schnittdaten					
			V(m/min)	f(mm/z)			ae(mm)	
				-PF	-PM	-PR		
<b>P</b> Low-carbon steel Soft steel Niedrig legierter Kohlenstoffstahl Baustahl	≤180	YBM251 YBC301	190 (170-250)	0.1 (0.08-0.15)	0.15 (0.1-0.25)	0.2 (0.2-0.3)	D	
		YBM351	150 (130-210)	0.1 (0.08-0.15)	0.15 (0.1-0.25)	0.2 (0.2-0.3)	D	
		YBG202 YBG205	190 (140-250)	0.1 (0.08-0.15)	0.15 (0.1-0.25)	0.2 (0.2-0.3)	D	
		YBG302	170 (130-250)	0.1 (0.08-0.15)	0.15 (0.1-0.25)	0.2 (0.2-0.3)	D	
	High-carbon steel Alloy steel Hoch Leg. Kohlenstoffstahl Leg. Stahl	180-280	YBM251 YBC301	170 (150-220)	0.1 (0.08-0.15)	0.15 (0.1-0.25)	0.2 (0.2-0.3)	D
			YBM351	140 (110-200)	0.1 (0.08-0.15)	0.15 (0.1-0.25)	0.2 (0.2-0.3)	D
			YBG202 YBG205	170 (130-250)	0.1 (0.08-0.15)	0.15 (0.1-0.25)	0.2 (0.2-0.3)	D
			YBG302	150 (110-230)	0.1 (0.08-0.15)	0.15 (0.1-0.25)	0.2 (0.2-0.3)	D
	Alloy tool steel Leg. Werkzeugstahl	280-350	YBM251 YBC301	150 (130-210)	0.1 (0.08-0.15)	0.15 (0.1-0.25)	0.2 (0.2-0.3)	D
			YBM351	130 (100-180)	0.1 (0.08-0.15)	0.15 (0.1-0.25)	0.2 (0.2-0.3)	D
			YBG202 YBG205	150 (110-240)	0.1 (0.08-0.15)	0.15 (0.1-0.25)	0.2 (0.2-0.3)	D
			YBG302	140 (80-210)	0.1 (0.08-0.15)	0.15 (0.1-0.25)	0.2 (0.2-0.3)	D
<b>M</b> Stainless steel Rostfreier Stahl	≤270	YBM251	110 (80-190)	0.1 (0.08-0.15)	0.15 (0.1-0.25)	0.2 (0.2-0.3)	D	
		YBM351	100 (80-170)	0.1 (0.08-0.15)	0.15 (0.1-0.25)	0.2 (0.2-0.3)	D	
		YBG202 YBG205	120 (80-190)	0.1 (0.08-0.15)	0.15 (0.1-0.25)	0.2 (0.2-0.3)	D	
		YBG302	100 (70-180)	0.1 (0.08-0.15)	0.15 (0.1-0.25)	0.2 (0.2-0.3)	D	
<b>K</b> Cast iron Gusseisen	180-250	YBG102	130 (80-180)	0.1 (0.08-0.15)	0.15 (0.1-0.25)	-	D	
		YBD152	140 (80-210)	-	0.15 (0.1-0.25)	-	D	
		YBD252	120 (80-210)	-	0.15 (0.1-0.25)	-	D	
<b>N</b>	Al alloy Al Leg.	----	YD101	300-	-LH		D	
			YD201	300-	0.2 (0.08-0.3)	D		

**B**

Milling Tools  
Fräser

- 3 Ramp milling, helical interpolation milling
- 3 Tauchfräsen, Spiral Interpolationsfräsen

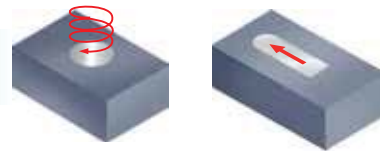

### Recommended cutting data · Empfohlene Schnittdaten

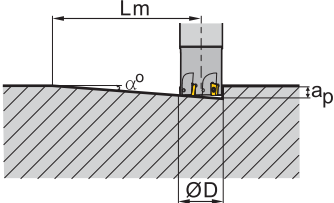
<p>• Ramp milling Tauchfräsen</p>  <p><math>L_m = \frac{a_p}{\tan \alpha}</math> (α: Maximum ramp angle) (α: Maximaler Eintauchwinkel)</p>	APKT Ramp milling, helical interpolation milling (Inserts—11) APKT Tauchfräsen, Spiral-Interpolationsfräsen				
	Ramp milling Tauchfräsen			Helical interpolation milling Spiral-Interpolationsfräsen	
	Diameter Durchmesser Ø D (mm)	Max. cutting depth Schnitttiefe $a_p$ (mm)	Max. ramp angle Eintauchwinkel $\alpha^\circ$	Min. length Länge $L_m$ (mm)	Min. diameter Durchmesser Ø D <sub>1</sub> (mm)
16	10.0	10.0	56.7	20.0	2.0
20	10.0	5.0	114.4	28.0	2.0
25	10.0	4.5	127.0	40.0	2.0
32	10.0	3.0	190.8	56.0	2.0
40	10.0	2.0	286.4	70.0	2.0

<p>• Helical interpolation milling Spiral-Interpolationsfräsen</p>  <p><math>\tan \alpha = \frac{P}{\pi D_1}</math> (α: helical angle) (α: Spiral Winkel)</p>
---

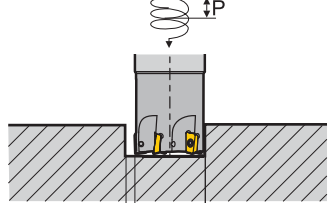
Applicable tool **B11-B18**  
Werkzeug

Tools code key **B26-B27**  
Werkzeug ISO

Grade selection guide **B19-B23**  
Sortenauswahl

Technical data **B215-B220**  
Technische Daten

# Milling · Fräsen

Indexable Milling Tools · Wendeplattenfräser

Case study for EMP01  
Bearbeitungsbeispiel für EMP01



Workpiece material: Cast Steel (HB220)  
Werkstück Material:

Cooling system: dry cutting  
Kühlsystem: trocken

Machine: vertical machining center  
Maschine: vertikales Maschinen-Center

Cutting data:  
Schnittdaten:  
Vc=180m/min  
ap=3mm  
fz=0.1mm/z

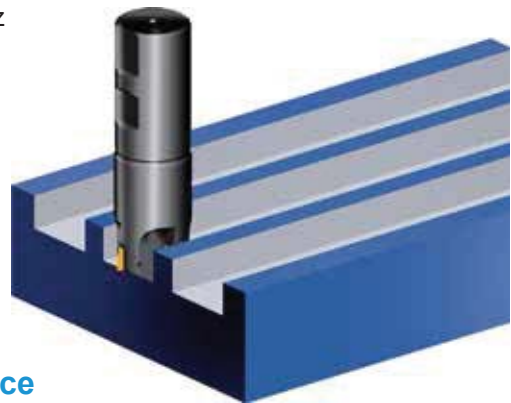

- Tool · Werkzeug : APKT160408-PM/YBC301
- Inserts · WSP : EMP01-040-XP32-AP16-04

- Wear comparison of insert after milling curved face
- Verschleißvergleich der WSP

**ZCC-CT**

Produkt of competitor  
Wettbewerbsprodukt

15'



25'

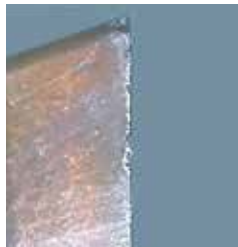

B

Milling Tools  
Fräser



### Square shoulder milling tools · Eckfräser

Kr:90°



EMPO2 P M K N

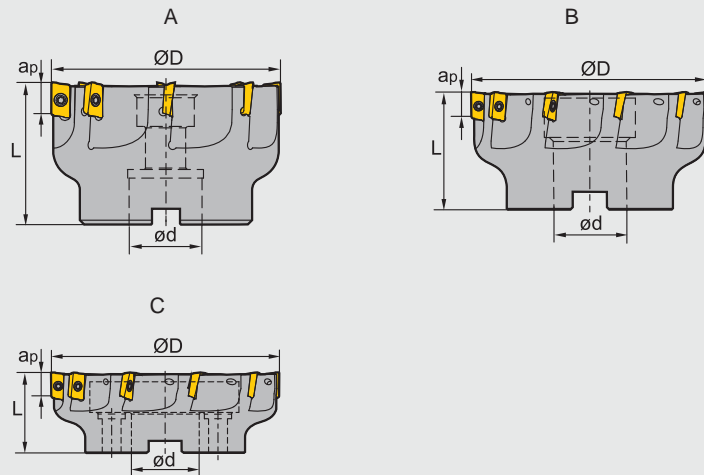

B

Milling Tools  
Fräser

### Specification of tools · Werkzeug Beschreibung

Type Typ	Stock Lager	Dimensions (mm) Abmessungen				No. of teeth Zähne	Coupling Aufnahme	Weight Gewicht (kg)
		Ø D	Ø d	L	apmax			
EMPO2 050-A22-AP11-06	●	50	22	40	11	6	A	0.3
050-A22-AP11-06C	●	50	22	40	11	6	A	0.3
063-A22-AP11-08	●	63	22	40	11	8	A	0.6
063-A22-AP11-08C	●	63	22	40	11	8	A	0.6
080-A27-AP11-08	●	80	27	50	11	8	A	1.2
080-A27-AP11-08C	●	80	27	50	11	8	A	1.2
100-B32-AP11-10	●	100	32	50	11	10	B	1.7
100-B32-AP11-10C	●	100	32	50	11	10	B	1.7
050-A22-AP16-05	●	50	22	40	15.5	5	A	0.3
050-A22-AP16-05C	●	50	22	40	15.5	5	A	0.3
063-A22-AP16-06	●	63	22	40	15.5	6	A	0.5
063-A22-AP16-06C	●	63	22	40	15.5	6	A	0.5
080-A27-AP16-07	●	80	27	50	15.5	7	A	1.1
080-A27-AP16-07C	●	80	27	50	15.5	7	A	1.1
100-B32-AP16-08	●	100	32	50	15.5	8	B	1.6
100-B32-AP16-08C	●	100	32	50	15.5	8	B	1.6
125-B40-AP16-10	○	125	40	63	15.5	10	B	3.2
125-B40-AP16-10C	○	125	40	63	15.5	10	B	3.2
160-B40-AP16-10	○	160	40	63	15.5	10	B	6.3
160-B40-AP16-10C	○	160	40	63	15.5	10	B	6.3
200-C60-AP16-12	○	200	60	63	15.5	12	C	8.1
250-C60-AP16-12	○	250	60	63	15.5	12	C	11.2

### Spare Parts · Ersatzteile

Diameter Durchmesser Ø D	Insert WSP	Screw Schraube	Wrench Schlüssel	
Ø50-Ø250	AP11	I60M2.5x6.5T	WT08IS	
Ø50-Ø250	AP16	I60M4x10	WT15IS	

Applicable tool B11-B18  
Werkzeug

Tools code key B26-B27  
Werkzeug ISO

Grade selection guide B19-B23  
Sortenauswahl

Technical data B215-B220  
Technische Daten



# Milling · Fräsen

## Indexable Milling Tools · Wendepplattenfräser

■ Applicable inserts · Wendeschneidplatten

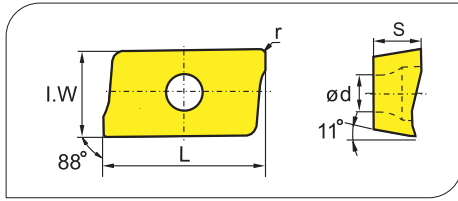

Workpiece Material Werkstoffe	Ideal Machining Condition Gute Bearbeitungsbedingungen		Normal Machining Condition Normale Bearbeitungsbedingungen		Unfavorable Machining Condition Ungünstige Bearbeitungsbedingungen	
	●	○	●	○	●	○
<b>P</b> Steel Stahl	●	○	●	○	●	○
<b>M</b> Stainless Steel Rostfreier Stahl	○	○	○	○	○	○
<b>K</b> Cast iron Gusseisen	○	○	○	○	○	○
<b>N</b> Non-ferrite material Ne Metalle	○	○	○	○	○	○
<b>S</b> Heat-resistant steel Wärmfester Stahl	○	○	○	○	○	○

# B

Milling Tools  
Fräser

Insert shape Plattenform	Type Typ	Dimensions (mm) Abmessungen					CVD Coating CVD Beschicht.						PVD Coating PVD Beschicht.				Cermet Cermet	Carbide uncoat. unbe. Hartmetall								
		L	I.W	S	d	r	YBC301	YBC302	YBC401	YBM251	YBM253	YBM351	YBD152	YBD252	YBG102	YBG202		YBG205	YBG302	YBG152	YBG252	YNG151	YNG151C	YC30S	YD101	YD201
	APKT11T304-PF	12.24	6.5	3.6	2.8	0.4	○		●						●	●	●									
	APKT11T308-PF	12.24	6.5	3.6	2.8	0.8			○							●										
	APKT11T312-PF	12.24	6.5	3.6	2.8	1.2										○										
	APKT11T316-PF	12.24	6.5	3.6	2.8	1.6										○										
	APKT160408-PF	17.877	9.33	5.76	4.4	0.8	●		○	●					●	●	●									
	APKT11T304-PM	12.24	6.5	3.6	2.8	0.4	●	●	●	●	●			●	●	●										
	APKT11T308-PM	12.24	6.5	3.6	2.8	0.8	●	●		●	●	●	●	●	●	●	●									
	APKT11T312-PM	12.24	6.5	3.6	2.8	1.2				○					○	●										
	APKT11T316-PM	12.24	6.5	3.6	2.8	1.6				●					○	●										
	APKT160408-PM	17.877	9.33	5.76	4.4	0.8	●	●	●	●	●	●	●	●	●	●	●	●								
	APKT11T304-PR	12.24	6.5	3.6	2.8	0.4			●		○						○									
	APKT11T308-PR	12.24	6.5	3.6	2.8	0.4											○									
	APKT11T312-PR	12.24	6.5	3.6	2.8	0.4											○									
	APKT11T316-PR	12.24	6.5	3.6	2.8	0.4											○									
	APKT160408-PR	17.877	9.33	5.76	4.4	0.8											○									
	APKT11T304-LH	12.24	6.5	3.6	2.8	0.4																	●	●		
	APKT11T308-LH	12.24	6.5	3.6	2.8	0.8																	●	●		
	APET160402-LH	17.877	9.33	5.76	4.4	0.2																	○			
	APKT160408-LH	17.877	9.33	5.76	4.4	0.8																	●	●		
	APET160408PDFR-LH	17.877	9.33	5.76	4.4	0.8																	○			

● Ex Stock / ab Lager ○ On demand / auf Anfrage

### Chipbreaker Selection · Spanbrecher Auswahl

Application Anwendung	Finishing Schlichten	Semi-Finishing Mittlere Bearbeitung	Roughing Schruppen
P	-PF	-PM	-PR
M	-PF	-PM	-PR
K	-PF	-PM	
AL	-LH		

### Square shoulder milling Eckfräsen

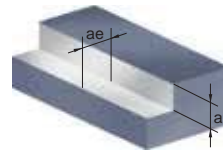

### Recommended cutting data · Empfohlene Schnittdaten

Workpiece material Werkstück Material	Hardness HB Härte	Grade Sorte	Cutting data Schnittdaten					
			V(m/min)	f(mm/z)			ae(mm)	
				-PF	-PM	-PR		
P Low-carbon steel Soft steel Niedrig legierter Kohlenstoffstahl Baustahl  High-carbon steel Alloy steel Hoch Leg. Kohlenstoffstahl Leg. Stahl  Alloy tool steel Leg. Werkzeugstahl	≤180	YBM251 YBC301	320 (240-400)	0.1 (0.08-0.2)	0.2 (0.1-0.3)	0.25(0.2-0.35)	≤0.5D	
		YBM351	260 (180-380)	0.1 (0.08-0.2)	0.2 (0.1-0.3)	0.25(0.2-0.35)	≤0.5D	
		YBG202 YBG205	320 (200-400)	0.1 (0.08-0.2)	0.2 (0.1-0.3)	0.25(0.2-0.35)	≤0.5D	
		YBG302	280 (180-400)	0.1 (0.08-0.2)	0.2 (0.1-0.3)	0.25(0.2-0.35)	≤0.5D	
	180-280	YBM251 YBC301	280 (210-380)	0.1 (0.08-0.2)	0.2 (0.1-0.3)	0.25(0.2-0.3)	≤0.5D	
		YBM351	240 (160-320)	0.1 (0.08-0.2)	0.2 (0.1-0.3)	0.25(0.2-0.35)	≤0.5D	
		YBG202 YBG205	280 (180-350)	0.1 (0.08-0.2)	0.2 (0.1-0.3)	0.25(0.2-0.3)	≤0.5D	
		YBG302	260 (150-380)	0.1 (0.08-0.2)	0.2 (0.1-0.3)	0.25(0.2-0.35)	≤0.5D	
	280-350	YBM251 YBC301	260 (180-350)	0.1 (0.08-0.2)	0.2 (0.1-0.3)	0.25(0.2-0.3)	≤0.5D	
		YBM351	220 (150-280)	0.1 (0.08-0.2)	0.2 (0.1-0.3)	0.25(0.2-0.35)	≤0.5D	
		YBG202	260 (160-330)	0.1 (0.08-0.2)	0.2 (0.1-0.3)	0.25(0.2-0.3)	≤0.5D	
		YBG302	240 (120-350)	0.1 (0.08-0.2)	0.2 (0.1-0.3)	0.25(0.2-0.35)	≤0.5D	
M Stainless steel Rostfreier Stahl	≤270	YBM251	200 (120-270)	0.1 (0.08-0.2)	0.2 (0.1-0.3)	0.25(0.2-0.3)	≤0.5D	
		YBM351	180 (150-300)	0.1 (0.08-0.2)	0.2 (0.1-0.3)	0.25(0.2-0.3)	≤0.5D	
		YBG202	200 (110-300)	0.1 (0.08-0.2)	0.2 (0.1-0.3)	0.25(0.2-0.3)	≤0.5D	
		YBG302	170 (100-280)	0.1 (0.08-0.2)	0.2 (0.1-0.3)	0.25(0.2-0.3)	≤0.5D	
K Cast iron Gusseisen	180-250	YBG102	220 (120-250)	0.1 (0.08-0.2)	0.2 (0.1-0.3)	-	≤0.5D	
		YBD152	240 (180-300)	-	0.2 (0.1-0.3)	-	≤0.5D	
		YBD252	200 (120-320)	-	0.2 (0.1-0.3)	-	≤0.5D	
N				-LH				
	Al alloy Al Leg.	----	YD101	300-	0.2 (0.08-0.4)			≤0.5D
			YD201	300-	0.2 (0.08-0.4)			≤0.5D

Applicable tool  
Werkzeug **B11-B18**

Tools code key  
Werkzeug ISO **B26-B27**

Grade selection guide  
Sortenauswahl **B19-B23**

Technical data  
Technische Daten **B215-B220**

# Milling · Fräsen

Indexable Milling Tools · Wendeplattenfräser

## Square shoulder milling tools · Eckfräser

Kr:90°



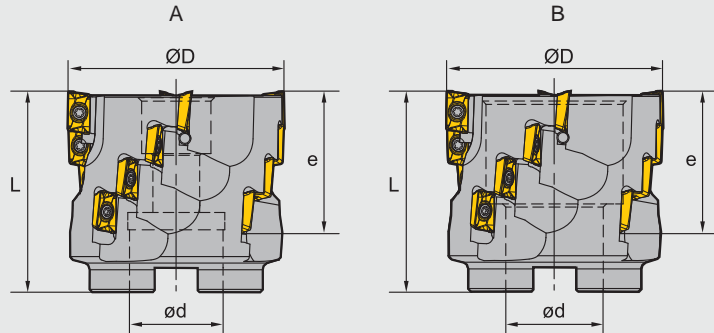
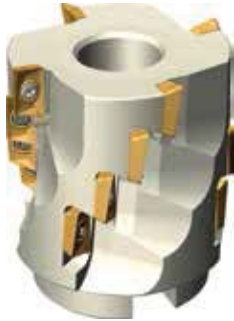

EMPO3 **P** **M** **K** **N**



### Specification of tools · Werkzeug Beschreibung

Type Typ	Stock Lager	Dimensions (mm) Abmessungen				Flute number Zahn- reihen z	No. of inserts WSP Anzahl	Coupling Aufnahme	Weight Gewicht (kg)	
		Ø D	Ø d	L	e					
EMPO3	●	-050-A22-AP11-04	50	22	58	39	4	16	A	0.5
	●	-050-A22-AP11-04C	50	22	58	39	4	16	A	0.5
	●	-063-A27-AP11-04	63	27	58	39	4	16	A	0.9
	●	-063-A27-AP11-04C	63	27	58	39	4	16	A	0.9
	●	-080-B32-AP11-05	80	32	63	39	5	20	B	1.3
	●	-080-B32-AP11-05C	80	32	63	39	5	20	B	1.3
	○	-100-B40-AP11-06	100	40	63	39	6	24	B	2.0
	○	-100-B40-AP11-06C	100	40	63	39	6	24	B	2.0

### Spare Parts · Ersatzteile

Diameter Durchmesser Ø D	Screw Schraube	Wrench Schlüssel	
Ø50-Ø100	 I60M2.5x6.5T	 WT08IS	

● Ex Stock / ab Lager ○ On demand / auf Anfrage

### Square shoulder milling tools · Eckfräser



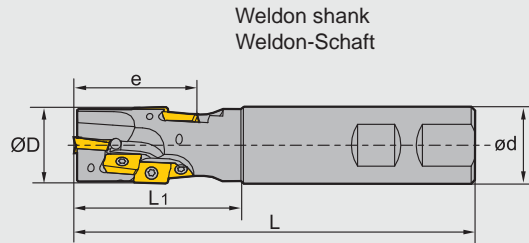

EMPO4 **P** **M** **K** **N**



### Specification of tools · Werkzeug Beschreibung

Type Typ	Stock Lager	Dimensions (mm) Abmessungen					Flute number Zahn- reihen z	No. of inserts WSP Anzahl	Weight Gewicht (kg)
		Ø D	Ø d	L	L1	e			
EMPO4	●	20	20	120	45	29.4	1	3	0.3
	●	20	20	120	45	29.4	1	3	0.3
	●	25	25	130	55	38.9	2	8	0.4
	●	25	25	130	55	38.9	2	8	0.4
	●	32	32	140	65	48.5	2	10	0.7
	●	32	32	140	65	48.5	2	10	0.7
	●	40	40	150	75	58.0	2	14	1.3
	●	40	40	150	75	58.0	2	14	1.3

### Spare Parts · Ersatzteile

Diameter Durchmesser Ø D	Screw Schraube	Wrench Schlüssel
Ø20-Ø40	 I60M2.5x6.5T	 WT08IS



Applicable tool **B11-B18**  
Werkzeug

Tools code key **B26-B27**  
Werkzeug ISO

Grade selection guide **B19-B23**  
Sortenauswahl

Technical data **B215-B220**  
Technische Daten

# Milling - Fräsen

## Indexable Milling Tools - Wendepplattenfräser

■ Applicable inserts - Wendeschneidplatten

● Ideal Machining Condition / Gute Bearbeitungsbedingungen  
 ● Normal Machining Condition / Normale Bearbeitungsbedingungen  
 ● Unfavorable Machining Condition / Ungünstige Bearbeitungsbedingungen

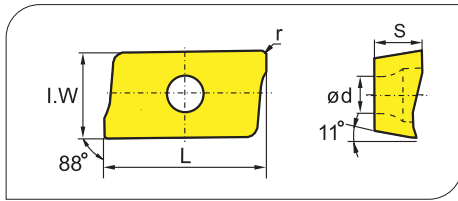

Workpiece Material / Werkstoffe	P	M	K	N	S
Steel / Stahl	●	●	●	●	●
Stainless Steel / Rostfreier Stahl	●	●	●	●	●
Cast iron / Gusseisen	●	●	●	●	●
Non-ferrite material / <i>Ne Metalle</i>	●	●	●	●	●
Heat-resistant steel / Warmfester Stahl	●	●	●	●	●

# B

Milling Tools  
Fräser

Insert shape / Plattenform	Type / Typ	Dimensions (mm) / Abmessungen					CVD Coating / CVD Beschicht.						PVD Coating / PVD Beschicht.				Cermets / Cermet		Carbide uncoat. / unbe. Hartmetall							
		L	I.W	S	d	r	YBC301	YBC302	YBC401	YBM251	YBM253	YBM351	YBD152	YBD252	YBG102	YBG202	YBG205	YBG302	YBG152	YBG252	YNG151	YNG151C	YC30S	YD101	YD201	
	APKT11T304-PF	12.24	6.5	3.6	2.8	0.4	○		●						●	●		●								
	APKT11T308-PF	12.24	6.5	3.6	2.8	0.8			○							●										
	APKT11T312-PF	12.24	6.5	3.6	2.8	1.2										○										
	APKT11T316-PF	12.24	6.5	3.6	2.8	1.6										○										
	APKT11T304-PM	12.24	6.5	3.6	2.8	0.4	●	●	○	●		●		●	●		●									
	APKT11T308-PM	12.24	6.5	3.6	2.8	0.8	●	●		●	●	●	●	●	●	●	●	●								
	APKT11T312-PM	12.24	6.5	3.6	2.8	1.2				○					○	●										
	APKT11T316-PM	12.24	6.5	3.6	2.8	1.6				●					○	●										
	APKT11T304-PR	12.24	6.5	3.6	2.8	0.4			●			○						○								
	APKT11T308-PR	12.24	6.5	3.6	2.8	0.4												○								
	APKT11T312-PR	12.24	6.5	3.6	2.8	0.4												○								
	APKT11T316-PR	12.24	6.5	3.6	2.8	0.4												○								
	APKT11T304-LH	12.24	6.5	3.6	2.8	0.4																	●	●		
	APKT11T308-LH	12.24	6.5	3.6	2.8	0.8																	●	●		
	APKT160408-LH	17.877	9.33	5.76	4.4	0.8																	●	●		

### ■ Chipbreaker Selection - Spanbrecher Auswahl

Application / Anwendung	Finishing / Schlichten	Semi-Finishing / Mittlere Bearbeitung	Roughing / Schruppen
P	-PF	-PM	-PR
M	-PF	-PM	-PR
K	-PF	-PM	
AL	-LH		

● Ex Stock / ab Lager ○ On demand / auf Anfrage

### Recommended cutting data · Empfohlene Schnittdaten

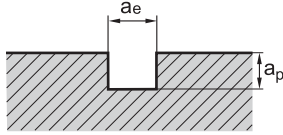
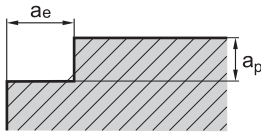
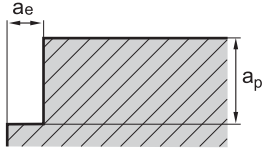
Slot milling Nutenfräsen	Square shoulder milling Eckfräsen	Deep square shoulder milling Tiefes Eckfräsen
		
ae=D ap:≤0.5D	ae:≤0.5D ap:≤1.2D	ae:≤0.2D ap<Cutting length of insert Schneidkantenlänge

Workpiece material Werkstück Material	Hardness HB Härte	Grade Sorte	Cutting data Schnittdaten				
			Square shoulder milling Eckfräsen				
			V(m/min)	f(mm/z)			
-PF	-PM	-PR					
<b>P</b> Low-carbon steel Soft steel Niedrig legierter Kohlenstoffstahl Baustahl	≤180	YBM251 YBC301	270 (240-350)	0.1 (0.08-0.2)	0.2 (0.1-0.3)	0.25(0.2-0.35)	
		YBM351	220 (180-300)	0.1 (0.08-0.2)	0.2 (0.1-0.3)	0.25(0.2-0.35)	
		YBG202 YBG205	270 (200-360)	0.1 (0.08-0.2)	0.2 (0.1-0.3)	0.25(0.2-0.35)	
		YBG302	240 (180-350)	0.1 (0.08-0.2)	0.2 (0.1-0.3)	0.25(0.2-0.35)	
	High-carbon steel Alloy steel Hoch Leg. Kohlenstoffstahl Leg. Stahl	180-280	YBM251 YBC301	240 (210-320)	0.1 (0.08-0.2)	0.2 (0.1-0.3)	0.25(0.2-0.35)
			YBM351	200 (160-280)	0.1 (0.08-0.2)	0.2 (0.1-0.3)	0.25(0.2-0.35)
			YBG202 YBG205	240 (180-360)	0.1 (0.08-0.2)	0.2 (0.1-0.3)	0.25(0.2-0.35)
			YBG302	220 (150-330)	0.1 (0.08-0.2)	0.2 (0.1-0.3)	0.25(0.2-0.35)
	Alloy tool steel Leg. Werkzeugstahl	280-350	YBM251 YBC301	220 (180-300)	0.1 (0.08-0.2)	0.2 (0.1-0.3)	0.25(0.2-0.35)
			YBM351	180 (150-250)	0.1 (0.08-0.2)	0.2 (0.1-0.3)	0.25(0.2-0.35)
			YBG202 YBG205	220 (160-340)	0.1 (0.08-0.2)	0.2 (0.1-0.3)	0.25(0.2-0.35)
			YBG302	200 (120-300)	0.1 (0.08-0.2)	0.2 (0.1-0.3)	0.25(0.2-0.35)
<b>M</b> Stainless steel Rostfreier Stahl	≤270	YBM251	170 (120-240)	0.1 (0.08-0.2)	0.2 (0.1-0.3)	0.25(0.2-0.35)	
		YBM351	160 (150-270)	0.1 (0.08-0.2)	0.2 (0.1-0.3)	0.25(0.2-0.35)	
		YBG202 YBG205	150 (110-270)	0.1 (0.08-0.2)	0.2 (0.1-0.3)	0.25(0.2-0.35)	
		YBG302	140 (100-250)	0.1 (0.08-0.2)	0.2 (0.1-0.3)	0.25(0.2-0.35)	
<b>K</b> Cast iron Gusseisen	180-250	YBG102	200 (120-240)	0.1 (0.08-0.2)	0.2 (0.1-0.3)	-	
		YBD152	240 (180-300)	0.1 (0.08-0.2)	0.2 (0.1-0.3)	-	
		YBD252	180 (120-300)	-	0.2 (0.1-0.3)	-	
<b>N</b> Al alloy Al Leg.	----	YD101	300-	-LH 0.2 (0.08-0.4)			
		YD201	300-	0.2 (0.08-0.4)			

Applicable tool  
Werkzeug **B11-B18**

Tools code key  
Werkzeug ISO **B26-B27**

Grade selection guide  
Sortenauswahl **B19-B23**

Technical data  
Technische Daten **B215-B220**

# Milling · Fräsen

## Indexable Milling Tools · Wendeplattenfräser

### Recommended cutting data · Empfohlene Schnittdaten

Workpiece material Werkstück Material	Hardness HB Härte	Grade Sorte	Cutting data Schnittdaten				
			Slot milling, deep square shoulder milling Nutenfräsen, Eckfräsen				
			V(m/min)	f(mm/z)			
-PF	-PM	-PR					
<b>P</b> Low-carbon steel Soft steel Niedrig legierter Kohlenstoffstahl Baustahl  High-carbon steel Alloy steel Hoch Leg. Kohlenstoffstahl Leg. Stahl  Alloy tool steel Leg. Werkzeugstahl	≤180	YBM251 YBC301	270 (240-350)	0.1 (0.08-0.15)	0.15 (0.1-0.25)	0.2 (0.2-0.3)	
		YBM351	220 (180-300)	0.1 (0.08-0.15)	0.15 (0.1-0.25)	0.2 (0.2-0.3)	
		YBG202 YBG205	270 (200-360)	0.1 (0.08-0.15)	0.15 (0.1-0.25)	0.2 (0.2-0.3)	
		YBG302	240 (180-350)	0.1 (0.08-0.15)	0.15 (0.1-0.25)	0.2 (0.2-0.3)	
	180-280	YBM251 YBC301	240 (210-320)	0.1 (0.08-0.15)	0.15 (0.1-0.25)	0.2 (0.2-0.3)	
		YBM351	200 (160-280)	0.1 (0.08-0.15)	0.15 (0.1-0.25)	0.2 (0.2-0.3)	
		YBG202 YBG205	240 (180-360)	0.1 (0.08-0.15)	0.15 (0.1-0.25)	0.2 (0.2-0.3)	
		YBG302	220 (150-330)	0.1 (0.08-0.15)	0.15 (0.1-0.25)	0.2 (0.2-0.3)	
	280-350	YBM251 YBC301	220 (180-300)	0.1 (0.08-0.15)	0.15 (0.1-0.25)	0.2 (0.2-0.3)	
		YBM351	180 (150-250)	0.1 (0.08-0.15)	0.15 (0.1-0.25)	0.2 (0.2-0.3)	
		YBG202 YBG205	220 (160-340)	0.1 (0.08-0.15)	0.15 (0.1-0.25)	0.2 (0.2-0.3)	
		YBG302	200 (120-300)	0.1 (0.08-0.15)	0.15 (0.1-0.25)	0.2 (0.2-0.3)	
<b>M</b> Stainless steel Rostfreier Stahl	≤270	YBM251	170 (120-240)	0.1 (0.08-0.15)	0.15 (0.1-0.25)	0.2 (0.2-0.3)	
		YBM351	160 (150-270)	0.1 (0.08-0.15)	0.15 (0.1-0.25)	0.2 (0.2-0.3)	
		YBG202 YBG205	150 (110-270)	0.1 (0.08-0.15)	0.15 (0.1-0.25)	0.2 (0.2-0.3)	
		YBG302	140 (100-250)	0.1 (0.08-0.15)	0.15 (0.1-0.25)	0.2 (0.2-0.3)	
<b>K</b> Cast iron Gusseisen	180-250	YBG102	200 (120-240)	0.1 (0.08-0.15)	0.15 (0.1-0.25)	-	
		YBD152	240 (180-300)	0.1 (0.08-0.15)	0.15 (0.1-0.25)	-	
		YBD252	180 (120-300)	-	0.15 (0.1-0.25)	-	
<b>N</b> Al alloy Al Leg.	----	YD101	300-	-LH 0.2 (0.08-0.3)			
		YD201	300-	0.2 (0.08-0.3)			

**B**

Milling Tools  
Fräser



### Square shoulder milling tools · Eckfräser

Kr: 90°



EMPO5 **P** **M** **K**

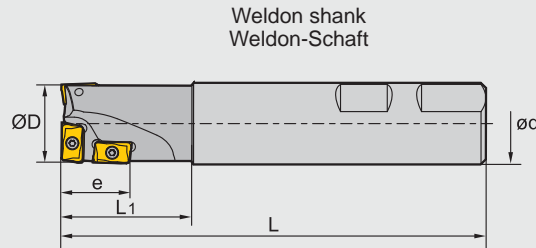

# B

Milling Tools  
Fräser

### ■ Specification of tools · Werkzeug Beschreibung

Type Typ	Stock Lager	Dimensions (mm) Abmessungen					No. of inserts WSP Anzahl		Weight Gewicht (kg)	
		R	Ø D	Ø d	L	L1	e	APMT11		APMT16
EMPO5	●	-025-XP25	25	25	130	40	20	3	--	0.5
	●	-025-XP25C	25	25	130	40	20	3	--	0.5
	●	-032-XP32	32	32	140	50	30	--	3	0.8
	●	-032-XP32C	32	32	140	50	30	--	3	0.8
	●	-040-XP32	40	32	150	60	40	--	4	1.0
	●	-040-XP32C	40	32	150	60	40	--	4	1.0

### ■ Spare Parts · Ersatzteile

Diameter Durchmesser Ø D	Insert WSP	Screw Schraube	Wrench Schlüssel	
Ø25-Ø40	APMT11	I60M2.5x6.5T	WT08IP	
	APMT16	I60M4x10	WT15IP	

Applicable tool **B11-B18**  
Werkzeug

Tools code key **B26-B27**  
Werkzeug ISO

Grade selection guide **B19-B23**  
Sortenauswahl

Technical data **B215-B220**  
Technische Daten

# Milling - Fräsen

## Indexable Milling Tools - Wendeschneidplattenfräser

■ Applicable inserts - Wendeschneidplatten

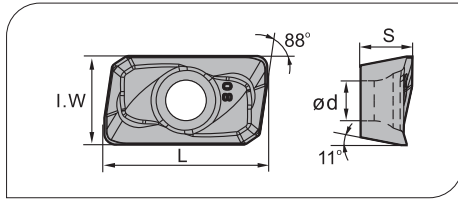

Workpiece Material Werkstoff	Ideal Machining Condition Gute Bearbeitungsbedingungen		Normal Machining Condition Normale Bearbeitungsbedingungen		Unfavorable Machining Condition Ungünstige Bearbeitungsbedingungen	
	●	●	●	●	●	●
<b>P</b> Steel Stahl	●	●	●	●	●	●
<b>M</b> Stainless Steel Rostfreier Stahl	●	●	●	●	●	●
<b>K</b> Cast iron Gusseisen					●	●
<b>N</b> Non-ferrite material Ne Metalle						●
<b>S</b> Heat-resistant steel Wärmfester Stahl					●	●

Insert shape Plattenform	Type Typ	Dimensions (mm) Abmessungen					CVD Coating CVD Beschicht.						PVD Coating PVD Beschicht.			Cermet Cermet		Carbide uncoat. unbe. Hartmetall							
		L	I.W	S	d	r	YBC301	YBC302	YBC401	YBM251	YBM253	YBM351	YBD152	YBD252	YBG102	YBG202	YBG205	YBG302	YBG152	YBG252	YNG151	YNG151C	YC30S	YD101	YD201
	<b>APMT1135PDR</b>	11.25	6.2	3.5	2.8	0.8				○					○	○	●								
	<b>APMT160408PDER</b>	17.25	9.25	4.76	4.4	0.8				○	○				○	●									

### 1 Drilling Bohren



### ■ Recommended cutting data - Empfohlene Schnittdaten

	Workpiece material Werkstück Material	Hardness HB Härte	Grade Sorte	Cutting data - Schnittdaten	
				V(m/min)	f(mm/z)
<b>P</b>	Low-carbon steel Soft steel Niedrig legierter Kohlenstoffstahl Baustahl	≤180	YBG202 YBG205	180 (150-220)	0.2 (0.08-0.25)
	High-carbon steel Alloy steel Hoch Leg. Kohlenstoffstahl	180-280	YBG202 YBG205	160 (130-200)	0.15 (0.08-0.2)
	Alloy tool steel Leg. Werkzeugstahl	280-350	YBG202 YBG205	140 (120-180)	0.12 (0.05-0.2)
<b>M</b>	Stainless steel Rostfreier Stahl	≤270	YBG202 YBG205	80 (50-150)	0.08 (0.03-0.15)
<b>K</b>	Cast iron Gusseisen	180-250	YBG202 YBG205	150 (100-220)	0.15 (0.08-0.2)

### 2 Milling Fräsen

### ■ Recommended cutting data - Empfohlene Schnittdaten

	Workpiece material Werkstück Material	Hardness HB Härte	Grade Sorte	Cutting data - Schnittdaten	
				V(m/min)	f(mm/z)
<b>P</b>	Low-carbon steel Soft steel Niedrig legierter Kohlenstoffstahl Baustahl	≤180	YBG202 YBG205	190 (140-250)	0.08 (0.04-0.15)
	High-carbon steel Alloy steel Hoch leg. Kohlenstoffstahl	180-280	YBG202 YBG205	170 (130-250)	0.08 (0.04-0.15)
	Alloy tool steel Leg. Werkzeugstahl	280-350	YBG202 YBG205	150 (110-240)	0.08 (0.04-0.15)
<b>M</b>	Stainless steel Rostfreier Stahl	≤270	YBG202 YBG205	120 (80-190)	0.08 (0.04-0.15)
<b>K</b>	Cast iron Gusseisen	180-250	YBG202 YBG205	120 (80-210)	0.08 (0.04-0.15)

● Ex Stock / ab Lager ○ On demand / auf Anfrage